

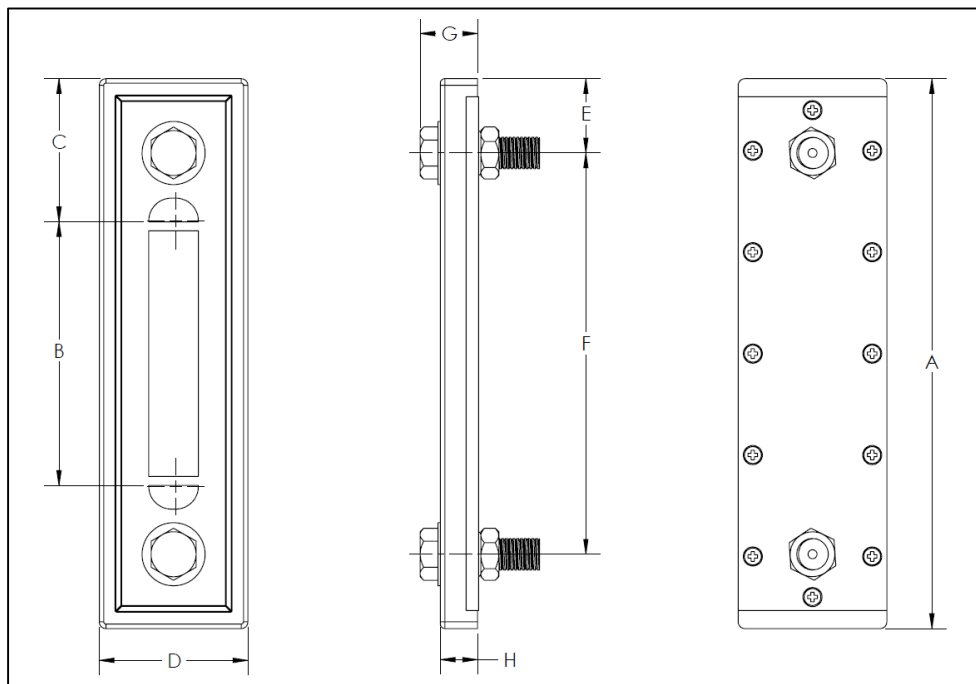

## FLUID LEVEL GAUGE

(MODEL: SGR – 3,5,7,10,14)

- Hydax introduces a newly designed Fluid level gauge of robust construction, bigger size and 'O' Ring sealing made from aluminium and glass filled nylon.
- Supplied in ready assembled condition, requiring only drilling of 2 holes making it easy to install.
- Available in 5 sizes : 3", 5", 7", 10", 14" between bolt centers.
- These level gauges also have the options of heat dial / thermometer temperature indicator.
- All Level Gauges sight glass is made with polycarbonate.



Model	A mm	B mm	C mm	D mm	E mm	F mm	G mm	H mm	Bolt Thread	Fixing Hole O mm	Temperature range		Weight in Kgs
											Deg C	Deg F	
SGR-3	127	45	41	50	25.5	76	47	23	M-12	12.5	30-80	86-176	0.265
SGRT-3	127	45	41	50	25.5	76	47	23	M-12	12.5			0.247
SGRD-3	127	45	41	50	25.5	76	47	23	M-12	12.5			0.25
SGR-5	172	90	41	64	22.5	127	47	23	M-12	12.5			0.35
SGRT-5	172	90	41	64	22.5	127	47	23	M-12	12.5			0.33
SGRD-5	172	90	41	64	22.5	127	47	23	M-12	12.5			0.35
SGR-7	240	130	55	63	31	178	50	23	M-14	14.5			0.53
SGRT-7	240	130	55	63	31	178	50	23	M-14	14.5			0.7
SGRD-7	240	130	55	63	31	178	50	23	M-14	14.5			0.7
SGR-10	350	180	85	76	48	254	53	25	M-16	17			2.0
SGRT-10	350	180	85	76	48	254	53	25	M-16	17			2.0
SGRD-10	350	180	85	76	48	254	53	25	M-16	17			2.0
SGR-14	450	280	85	76	47	356	53	25	M-20	21			2.73
SGRT-14	450	280	85	76	47	356	53	25	M-20	21			2.73
SGRD-14	450	280	85	76	47	356	53	25	M-20	21			2.73

### HYDAX HYDRAULICS PVT. LTD.